



LINDEMANN.
high fidelity excellence



822

Super Audio CD Player

Owner's Manual

ENGLISH

Important Safety Precautions

- Use only an approved power cable and plug or distribution board to connect your player to a power outlet. Do not use an extension cable.
- Never touch the mains plug if your hands are wet.
- Do not attempt to open the equipment. The invisible laser beam in this compact disc player is harmful to the eyes. Refer servicing and repair to qualified service personnel. Touching live components inside the case can result in a fatal electrical shock!
- Read the Owner's Manual and Safety Precautions before operating the equipment.
- Keep this Manual in a safe place so that you can refer to it later.
- Please heed all warnings on the equipment itself and in the Owner's Manual.
- Please follow the instructions contained in your Owner's manual and never use this equipment for any purpose other than is explained in this Owner's Manual.
- Only connect this equipment to a power source of the type described in the Owner's Manual and specified for this equipment.
- Make sure that there is adequate ventilation around the equipment to allow proper cooling. Keep the equipment away from direct sunlight. Avoid installing the unit close to sources of heat or in spaces such as bookshelves or cupboards where heat radiation may be obstructed. Avoid excessive temperatures in the room, as these could ultimately damage sensitive components and reduce the service life of your player.
- Never use the unit in damp rooms, at temperatures of below 10°C, or in the open air. When bringing your player in from the cold, allow it time to achieve room temperature before plugging it in.
- Always switch the unit off before removing or inserting interconnects. Doing this with the player switched on can damage not only the player itself but also equipment connected to it.
- If you ever spill water or any other liquid onto the equipment: Do not touch the case! Remove the plug from the wall outlet and contact your dealer or our service department.
- Never remove the earth connection from the plug. It is there to ensure your safety.
- Arrange the power cable so that no one can accidentally stand on it. Avoid locating it under objects that might put pressure on the cable. Pay particular attention to areas where the cable exits from plugs, AC outlets and from the unit itself.
- Never operate the unit without being present. Disconnect the plug from the wall outlet and remove all aerial connections (including cable aerials) when: you clean the unit, you do not expect to use the unit for long periods of time, during an electrical storm.
- If you have an external antenna or cable antenna connected to your hi-fi system, we recommend that you use a signal isolating filter to avoid interference or damage during thunderstorms.
- Problems: If you lose the sound while the player is operating, or if you notice smoke or burning, switch the unit off immediately and contact your dealer or our service department.
- Only replace defective fuses after you have traced and removed the cause of the fault and then only with a fuse of the same rating. Remove the mains plug before changing fuses. Use an insulated screwdriver to remove and replace the fuse.

Copyright and trade mark acknowledgements



CD, Compact Disc Digital Audio and their respective logos are registered trademarks of SONY and PHILIPS.



SACD, Super Audio CD, DSD, Direct Stream Digital and their respective logos are registered trademarks of SONY and PHILIPS.

HiDRA, Lindemann audiotechnik, Lindemann high fidelity excellence and the Lindemann logo are registered trade marks of Lindemann audiotechnik GmbH. Lindemann audiotechnik GmbH disclaims any proprietary interest in trade marks and trade names other than its own.

The information in this manual is furnished for information use only, is subject to change without notice, and should not be construed as a commitment by Lindemann audiotechnik GmbH. Lindemann audiotechnik GmbH assumes no responsibility or liability for any errors or inaccuracies that may appear in this manual.

Copyright and Acknowledgements

Copyright © 2007 Lindemann audiotechnik GmbH. All rights reserved.

No part of this publication may be reproduced, stored in a retrieval system, or transmitted, in any form or by any means, electronic, mechanical, photocopying, recording, or otherwise, without the prior written permission of the publisher.

Dear Music Lover,

Congratulations on becoming the owner of this new SACD player. The 822 is an exclusive high-end audio component, built in Germany in limited quantities.

Our team designed this CD player to the highest standards so that you could enjoy the highest level of audio reproduction. Because we use only the finest components and the most modern production technologies, we confidently guarantee that our products will retain their superb qualities for many years.

Keep the carton and packaging materials that your 822 came in. They will protect your CD player should you need to transport it in the future. Transporting the 822 in anything other than the original packaging may result in physical damage not covered by your warranty.

A final note: Please take the time to read this Owner's Manual before using the equipment for the first time. It contains a number of useful tips gathered from our many years of experience, which will help you get the most from your hi-fi system.

Table of Contents

Accessories supplied	5
Front view	7
Rear view	8
Remote control	10
Setting up	11
Basic CD/SACD functions	12
Switching on and off	12
Loading a CD/SACD	12
Playing the disc	12
Switching between CD and SACD	12
Stopping playback	13
Playing a specific track	13
Skip/Search	13
Program play	14
CD Text	14
Configuration menus	15
Digital Output	15
Display Info	15
Absolute Phase	16
Display Brightness	16
Reset to Default (factory settings)	16
Link Mode	17
The different CD formats	17
The different CD formats	18
Handling compact discs	18
Troubleshooting	19
Specification	20
CE declaration of conformity	21
Guarantee and Service	22
Directive on waste electrical and electronic equipment	23

Accessories supplied

- 822 SUPER AUDIO CD PLAYER
- Power cord, 2.0m
- SYSCOM connector cable, 1.0m
- Owner's Manual
- Warranty Card

We recommend that you keep the packaging for use when transporting the 822 in the future.

822 Super Audio CD Player

- Place your SACD player on a stable support and use a spirit level to make sure it is perfectly level. We recommend the use of a solidly constructed hi-fi rack with adjustable shelves. In our experience, you will achieve good results with racks using MDF shelves. Glass, metal or stone are less suitable for use as hi-fi equipment supports. Avoid placing the player close to loudspeakers or any other source of vibration. The 822 will respond to these measures by performing at its best. Never stack the 822 directly on other items of equipment. Vibrations from mains transformers and electromagnetic interference from other components can have a negative impact on the player's sound quality. 800 series products are not suitable for installation in enclosures such as 19" racks or cabinets. The on/off switch at the rear of the unit must always be accessible.
- Take some time to organize your cabling. Try to keep power cables away from interconnect and speaker cables. Shielded power cords can significantly reduce the transfer of interference to your signal cables.
- Make sure that the polarity of the mains wiring is the same for all system components. You can achieve this by connecting all system components through a **single** high quality mains distribution board. The lower the contact resistance between the power outlets of your signal source and your amplifier, the less the audio signal will be polluted and the better your hi-fi system will sound. Connecting your components with the correct mains polarity is particularly important. Use a phase tester to determine which pole is live. Mark the appropriate side. Connect the marked side of the 822 power plug to the positive conductor of your power outlet/distribution board.
- Cleaning and maintenance: To clean your CD player, use a soft cloth. Use a proprietary glass cleaner to remove stubborn dirt from the front panel. Do not use water! Never use solvents or white spirit. These will cause irreparable damage to the surface of the unit.

Front view

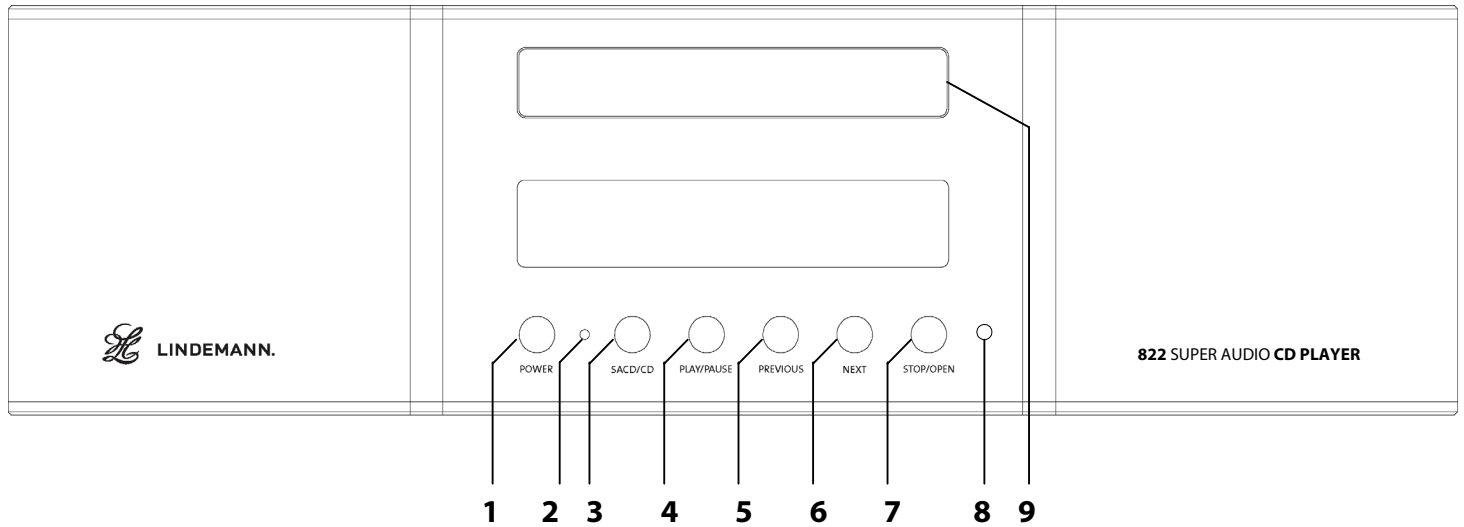

- | | |
|---------------------|---------------------|
| 1 Power button | 6 Next button |
| 2 Standby LED | 7 Stop/Open button |
| 3 CD/SACD button | 8 Infrared receiver |
| 4 Play/Pause button | 9 CD drawer |
| 5 Previous button | |

Power button

The power button switches the player on and off. To switch the unit on, plug it into a power outlet and press the power switch on the rear panel (position I).

Standby LED

When the 822 is in standby mode, the standby LED will illuminate. When the 822 is operational, the standby LED goes out and only the display illuminates. When you switch the unit off, the standby LED flashes for around 5 seconds. It is not possible to switch the player on again during this time. When the 822 has been unplugged from the wall socket, or when the power switch is in position 0, neither the standby LED nor the display will illuminate.

CD/SACD button

Allows you to change between the CD or SACD format with hybrid SACDs. When you load a hybrid CD, the 822 automatically selects the SACD format. If you wish to play back the CD layer of the hybrid disc, press the STOP button and then the CD/SACD button.

Infrared receiver

The infrared receiver picks up the commands sent from the remote control. For the remote control system to operate properly, you should ensure that there is a clear line of sight between the receiver and the remote handset.

Rear view

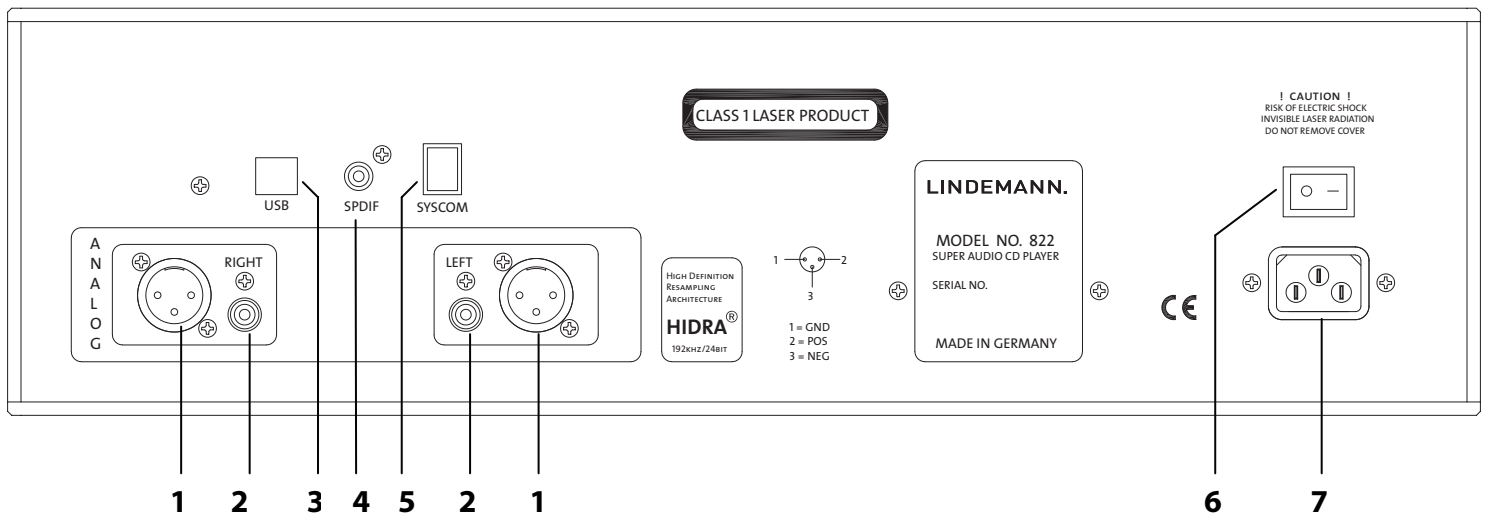

- | | |
|--|--|
| <p>1 Analog output, XLR
2 Analog output, RCA phono
3 USB connector
4 Digital output, S/P DIF</p> | <p>5 SYSCOM connector
6 Power (on/off) switch
7 AC supply socket</p> |
|--|--|

Analog output

The 822 has both balanced (XLR) and unbalanced (RCA) analog outputs. Connect these to the appropriate inputs on your amplifier.

When inserting the cables, check that the plugs fit tightly in their sockets! Poorly fitting phono plugs can detract considerably from the sound quality of your system. Use gold-plated plugs whenever possible, as these have the lowest contact resistance.

Digital output

The digital output provides a standard 16-bit, 44.1kHz SPDIF-AES/EBU signal for connecting to an external DAC digital clock signal processor. **The digital output works only in CD mode.**

To ensure correct operation, use only a high quality digital cable of the correct impedance (RCA = 75 ohm).

USB port

The USB port is provided solely for service purposes.

Power connection

The power inlet is designed to take a removable IEC cable. We recommend you use a high quality audiophile power cable. Your dealer will be able to advise you!

Power (on/off) switch

The on/off switch disconnects the 822 fully from the AC mains supply.

SYSCOM

This connection lets you network several 800 series products so that you can control the switching and display operation of several components from a single controller. To take advantage of this feature you need an appropriate power amplifier or preamplifier. You should switch off all system components before changing SYSCOM cables. Use only the SYSCOM cables supplied. Do not use any other type of cable, as this could damage your equipment! If you need longer SYSCOM cables, please contact Lindemann audioteknik directly (see back page for contact details) or your dealer. You will find a detailed description of all Link Mode functions in the Link Mode section.

Remote control

1. Power button

Switches the unit on and off from standby.

2. Track select buttons

Direct track selection.

3. Menu selection

DAC menu:

selects the menu for configuring the converter functions.

4. Cursor

UP/DOWN/LEFT/RIGHT: Selecting the menu items
OK: Confirming your selection

5. Transport function

Please refer to 'Basic CD/SACD functions'

6. Additional functions

Info:

When you press the INFO button, the display will show all important basic settings.

These settings are:

- Play/Pause
- CD/SACD
- REPEAT

program/ check/ clear

For programming the order of tracks. Please refer to 'Program play'.

time/text:

Changes the CD/SACD information display format. See 'CD TEXT'

A-B:

Repeating a section.

Repeat:

Repeating a track or an entire CD/SACD.

CD/SACD:

Changing from CD to SACD format, and vice versa.

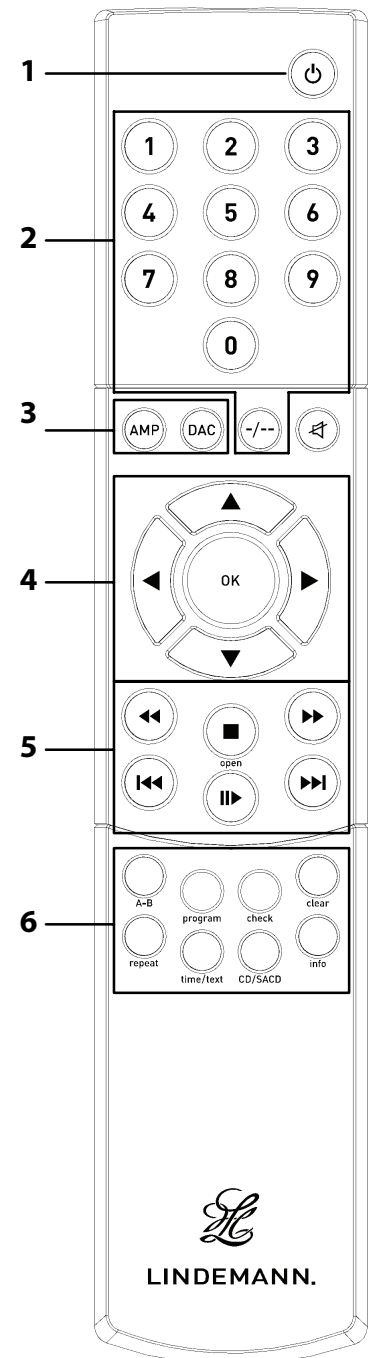

When using the remote control, always point it directly at the player. Please remember that direct sunlight or artificial light (particularly fluorescent lighting) can affect the signal.

Weak batteries will considerably reduce the range of the remote control. Always replace batteries with new ones of the same type.

To change the batteries, open the battery compartment cover on the rear of the remote handset. Take out the discharged batteries and replace them with new ones of the same type (Alkaline AAA), making sure that they are positioned as shown on the drawing in the battery compartment.

Please dispose of your used batteries carefully. Stores that sell batteries often provide containers for recycling used batteries. You can also dispose of them at your nearest recycling centre.

Setting up

- Switch off the power switch on the rear of the 822.
- Remove the transport screw from the bottom panel. Then remove the protective strip from the CD drawer. Retain the transport screw and the protective foil strip with your packaging. These will be needed if you wish to transport the 822 at some time in the future.
- **Always protect the player well before transporting it.** To do this, proceed as follows: With the player switched on, press the Stop/Open button to close the drawer. Switch the unit off using the rear-mounted power switch. Insert the foil strip in the gap between the drawer and the front panel. Turn the player over so that it is standing vertically on its rear. (Place it on a soft surface such as a carpet or tablecloth to avoid scratching the surface of your player). Tighten the transport screw in the hole in the bottom panel. Use *hand pressure* only. Do not use tools to tighten the screws!
- Connect the D 822 to your amplifier using a suitable interconnect cable. Connect the SACD into the AC outlet - preferably using a high quality power cable. The cable supplied with your player is just to get you started. We strongly recommend that you use a high quality power cable. Make sure that the voltage shown on the model identification plate matches the voltage of your mains supply. If you intend to swap interconnects at any time in the future, always remember to switch the player off first. Failure to do so could damage the unit. If you have other 800-Series components in your system, connect these with the SYSCOM cables supplied.
- For safety reasons, the remote control is supplied without the batteries installed. Please insert the batteries supplied, observing the polarity marks shown on the battery compartment.
- We have provided controls on the front panel to allow you to access the important control functions of the 822. The remote control allows you to access these and all the other functions of the unit.

- Turn the SACD player on using the on/off switch on the rear panel. Your SACD player is now in standby mode and ready for use. This is indicated by the blue Standby LED.

Basic CD/SACD functions

Switching on and off

To switch the unit on, press the Power button on the front panel or on the remote control.

To switch the player off, press the Power button again. This will switch the SACD player into standby mode. You will see this message in the display: *Power Down...* This will disappear after a short interval. The blue standby LED will flash for about 5 seconds. It is not possible to switch the player on again during this time.

Use the Power button to switch the unit on and off in everyday use. When the SACD player is connected via the SYSCOM cable to a Lindemann power amplifier, the Power button will also control the power amp. If a preamplifier is also connected, it will handle the switching of all the system components.

Loading a CD/SACD

Press the STOP/OPEN button to open the CD drawer. Wait until you see *OPEN* showing on the display. Now place a CD or SACD in the drawer. The printed label side must be at the top.

To close the drawer, press the STOP/OPEN button again. The drawer will retract. If you fail to press the STOP/OPEN button within a minute, the drawer will close automatically.

As the player reads the contents of the disc, the display window reads: *TOC Reading...*

Once the player has scanned the CD/SACD, it displays the number of tracks, the total playing time and the CD Text.

If you have loaded a hybrid disc, the SACD track will be selected automatically.

Playing the disc

Press the PLAY/PAUSE button to play the CD/SACD. The track number, the index and the playback time will be shown in the display. If the disc supports CD Text, the title is also displayed.

Switching between CD and SACD

With hybrid discs you can choose to play either the standard CD or the SACD version. To change from SACD to CD and vice versa, first press the STOP/OPEN button to stop playback. Then press the SACD/CD button to get the player to rescan the disc. The playback format of the track being played appears in the display. (If you wish to hide this information, you can do so via the Display menu)

Stopping playback

Use the PLAY/PAUSE button to pause playback. Press the PLAY/PAUSE button once again to resume. Press the STOP/OPEN button to stop playback. If there is no CD/SACD in the player, or if playback has finished, press the STOP/OPEN button to open the drawer.

Playing a specific track

You can play a specific track by entering its number on the numeric keypad (1-9). Use the -/-- button to enter numbers larger than 9. For example, if you wish to play track 21, first press the -/-- button, then 2 and then 1.

Skip/Search

The SKIP button lets you go skip one or more tracks. Press the ►► button on the remote control, or the Next button on the front panel, to play the next track. Press the ◀◀ button on the remote control, or the Previous button on the front panel, to go back to the beginning of the track you are currently playing. You can skip through several tracks by pressing the button repeatedly.

The SEARCH buttons ►► ◀◀ on the remote control allow you to locate a specific place within a track.

Repeat

The REPEAT button lets you repeat individual tracks, a complete CD, or specific sections. Press the REPEAT button once to repeat the entire CD.

The display shows: < Repeat >

Press twice to repeat the last track played.

The display shows: < Repeat 1 >

To cancel the REPEAT function, press the REPEAT button again.

The display shows: < Repeat off >

Display Info in the configuration menu provides you with an option to show or hide Repeat in the display.

Repeating a section

You can repeat a specific passage within a track using the A-B button. A refers to the beginning and B to the end of the passage.

- Press the A<->B button as soon as you reach the section of music that you wish to repeat.
- You will see this message in the display: *Repeat A*.
- The flashing **A** warns that you still have to set the finish point **B**.
- Press A<->B again when you reach the end of the passage that you wish to repeat. The passage you have selected will now be repeated continuously until you press the REPEAT button again.

Program play

You can programme the order in which the tracks of a CD/SACD are played.

When the player has read the contents of the CD/SACD, press the PROGRAM button. Use the numeric keypad (1-9) and the -/-- button to enter the number of each track you wish to play. Enter the tracks in the order in which you wish to listen to them. The tracks will be stored automatically. The display will show the number of tracks entered and the total playing time for the playlist.

You can store up to 32 tracks in one playlist. If you wish, you can store the same track several times in the same playlist.

Use the CLEAR button if you wish to delete the last track you entered. You can press the CLEAR button as often as you like to remove any number of tracks from your list, starting from the end of your programme. Hold the CLEAR button down for longer than 3 seconds to clear the entire playlist.

You can check the contents of your playlist using the CHECK button. Each time you press the CHECK button, the number in the display advances by one track (starting from the beginning of the playlist) and shows the total playing time to date (up to the current track).

After programming your playlist, press the PLAY/PAUSE button to listen to your selection.

CD Text

CD Text contains information about the CD/SACD such as the title or the name of the artist. This data is stored in an area of the CD/SACD that is not used on 'normal' CDs.

When you load a CD/SACD containing text information, the player reads this information and displays the album title. To display the artist's name, press the TIME/TEXT button on your remote control. Pressing the TIME/TEXT button again displays the total playing time and number of tracks.

The display shows the name of the current track while the CD/SACD is playing. Pressing the TIME/TEXT button brings up the playing time of the current track, the playing time of the whole CD/SACD and the remaining playing time of the CD/SACD.

When a track or artist name has more than 14 characters, the display shows the first 14 characters and then scrolls to the end of the name.

During playback of CD/SACDs with no CD Text content, only the time information is displayed.

Configuration menus

The 822 provides many adjustment options in addition to the basic controls. You will find these functions in DAC Setup. To access the setup menu, press the DAC button. Use the LEFT or RIGHT buttons to navigate within the menu. Press the OK button to alter a setting. In the menu, you can use the Setup button to navigate back, i.e. to move back one level without changing any settings. To quit Setup, press the Setup button repeatedly until the standard display reappears.

The available settings are shown as follows:

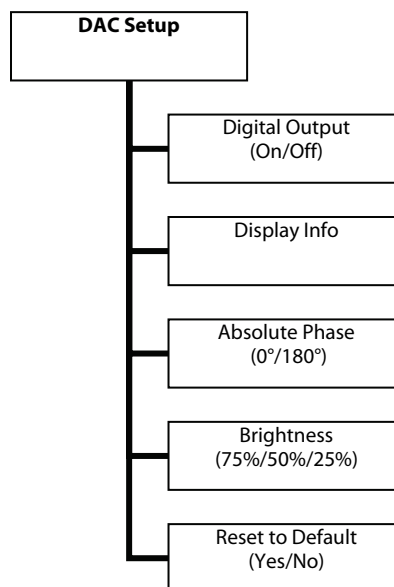

Digital Output

You can switch the digital output on or off using the LEFT or RIGHT button. To confirm a change, press the OK button.

The digital output is only available in CD mode.

Display Info

Setting of the default display information. You can choose to show PLAY/PAUSE, REPEAT or CD/SACD permanently in the display. To select the information you wish to display, press the UP or DOWN button. You can alternate between "Display Yes / No" using the LEFT or RIGHT button. To confirm a change, press the OK button.

Even when the display is switched off, you can view all the default information for a few seconds by pressing the INFO button on your remote control.

Absolute Phase

Certain recordings sound better when you change the polarity of the audio signal, although the difference is minimal with most recordings.

Set the phase of the analog output signal to 0° or 180° using the LEFT or RIGHT button. To confirm a change, press the OK button. When the 822 is connected to the 830 preamplifier via the SYSCOM cable (Link Mode), absolute phase is set by the preamplifier and the Absolute Phase menu is no longer available on the 822.

Display Brightness

When you use the 822, its display is set to maximum brightness. After about 20 seconds, the display will change to the brightness setting you have specified from this menu. To avoid wearing out the display prematurely, do not set the display brightness too high.

You can choose three brightness levels (75%, 50% or 25%) using the LEFT or RIGHT button. To confirm a change, press the OK button. When the 822 is connected to the 830 preamplifier via the SYSCOM cable (Link Mode), the preamplifier takes control of the display and the Brightness menu is no longer available on the 822.

Reset to Default (factory settings)

Use this option to restore the configuration menu to the standard settings. To do this, press the LEFT and OK buttons to confirm Yes when you see the reset warning message.

Link Mode

The 822 is able to communicate with other compatible Lindemann components via the SYSCOM system. The Link Mode allows you to operate all of your Lindemann components from a single remote control.

To use this feature, all components must be linked with a SYSCOM cable (see diagram below). You must switch off all system components before changing any of the SYSCOM connections, as a re-start is required to ensure that the system recognizes all of the components.

If a preamplifier is also connected, it will assume control of the other components in the system.

This means that some of the functions and menu items on the 822 will also change.

These changes are as follows:

- The display brightness is controlled from the preamplifier. The Brightness menu option (display brightness) is no longer available. *If the Link is removed, the previous display brightness settings on the 822 are restored.*
- The *Absolute Phase* menu option is no longer available. The preamplifier takes control of this setting.
- *DAC Setup* is carried out using the controls on the preamplifier. When you use the remote control to make changes in DAC Setup, please make sure that there is clear line of sight from the remote to the preamplifier, which must process the commands from the remote control.

Important: You can only control the 822 CD player and the 830 preamplifier with the same remote control when Link Mode is active: otherwise, both components could react simultaneously to certain commands (such as volume, etc.). The two components should be positioned directly adjacent to or above and below each other to ensure that both remote sensors receive commands from the system remote at the same time.

The SYSCOM connections are:

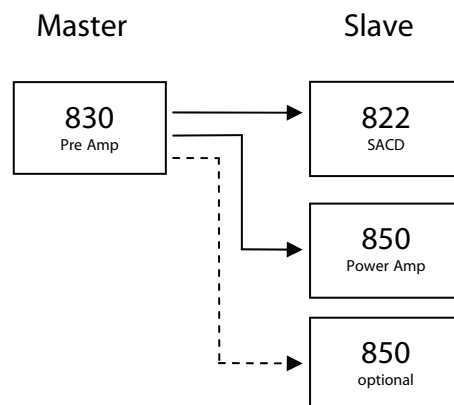

The different CD formats

The 822 plays compact discs (CD), CD-recordable discs (CD-R), and Super Audio Compact Discs (SACD). These bear the symbols:



Super Audio CD uses the DSD recording process. Unlike 'normal' CDs, which are based on 16-bit PCM converter technology, SACDs employ a 1-bit A/D converter during the recording process that operates at a sampling frequency of 2.8224 MHz - 64 times higher than CD. During recording and playback, SACDs high resolution datastream does not require the use of filters that may degrade the sound. Because of this, it is possible to reproduce frequencies up to 100 kHz, which not only makes the reproduction of high frequencies more natural but also delivers a noticeably superior sound stage. The technology also offers a greater dynamic range.

Because of differences in the quality of blank discs, it is possible that some **CD-Rs** might not be readable. Lindemann audiotechnik cannot guarantee that the player will read **CD-RWs** (re-writable CDs) perfectly. However, tests with a number of CD-RW brands have shown that very good results are possible.

Handling compact discs

Please follow these guidelines:

- Never subject CD/SACDs to high temperatures or leave them in direct sunlight. They may warp.
- Try to hold the CD/SACD only by its edges. Dirt, writing, scratches or adhesive labels can impair the reproduction quality of CD/SACDs and even render discs unplayable.
- We strongly recommend you avoid CD/SACD 'tweaking' using methods such as adhesive rings, felt pens and polishing. Such tweaks can damage your CD/SACDs and make them unplayable.
- Because of the high rotational speed of an SACD, never use CD mats or similar. They can result in damage to the transport mechanism.
- Use a dry, soft cloth to wipe dust and fingerprints from the surface of discs. Wipe from the centre to the outside edge without applying pressure. Never use chemical cleaning agents.

Troubleshooting

The display is dark and the unit does not work:

- The 822 is in standby mode. -> Press the POWER button
- The 822 is not connected to a power outlet, or the power switch (on the rear panel) is in the 'off' position. -> Plug the 822 into a power outlet and switch the unit on.

The display illuminates but there is no sound:

- There is no CD/SACD in the machine -> load a CD/SACD
- Play the disc.
- You have selected the wrong input on your amplifier.
- The volume setting is too low.

No Disc is showing in the display:

- There is no CD/SACD in the machine. -> Load a CD/SACD
- The CD/SACD has not been placed correctly in the drawer. -> Place the CD/SACD in the drawer with the label side up.
- The CD/SACD is badly scratched or damaged.

The unit does not respond to the remote control:

- The remote control batteries are discharged or have been inserted incorrectly. -> Change the batteries.
- The distance, or angle, between the remote control handset and the 822 is too great.
- The IR receiver on the 822 is obstructed. -> Make sure that there is clear line of sight between the remote control and the IR receiver.

Specification

Measuring conditions: 22°C, 230V supply voltage.

Dimensions	440 x 135 x 342 mm (W x H x D incl. feet)
Weight	13.8kg
AC supply.....	230V 50/60Hz
Power consumption	28W maximum
Power consumption	18W idle
Power consumption in standby	1.8W

CD converter

S/N (A-weighted).....	-120dB
THD & noise (quantization)	-99dB
Frequency response.....	0Hz – 22.000 Hz (-3dB)
Dynamic range.....	125 dB
DAC	24-bit, 192 kHz

SACD converter

S/N (A-weighted).....	-120dB
THD & noise (quantization)	-106dB
Frequency response.....	0Hz – 38.000Hz (-3dB)
Dynamic range.....	144dB

Analog outputs:

Unbalanced

Output voltage	2.3V
Output impedance	50 ohms

Balanced

Output voltage	4.6V
Output impedance	100 ohms

Digital outputs:

Coaxial, SPDIF

Output voltage	0.5V pp
Output impedance.....	75 ohms

Please note:

Our product policy is one of continuous development. Specifications are therefore subject to change without notice.

CE declaration of conformity

Product type: CD player

Model: 822 SUPER AUDIO CD PLAYER

LINDEMANN audiotechnik GmbH declares that this product complies with the Low Voltage Directive 73/23/EEC and the Electromagnetic Compatibility Directive 89/336/EEC, amended by the directives 92/31/EEC and 93/68/EEC.

The conformity of the designated product with the provisions of directive number 73/23/EEC (LVD) is proved by full compliance with the following standards:

EN 60065 (Date of issue 1998)

The conformity of the designated product with the provisions of directive number 89/336/EEC (EMC) is proved by full compliance with the following standards:

EN 55013 (Date of issue 2001)

EN 55020 (Date of issue 2002)

Guarantee and Service

At Lindemann we value our customers. When a Lindemann product leaves our factory we do not see this as the last step of the process, rather it is the beginning of our long-standing relationship with you. Thereafter we seek to support you in every way that we can. Should you require any further information feel free to contact us at Lindemann audiotechnik.

This product is guaranteed under the conditions that apply in the country of purchase and your statutory rights are not limited. In addition to any statutory rights you may have, Lindemann undertake to replace any parts that have failed due to faulty manufacture. To help us, please ask your Lindemann retailer about the Lindemann warranty scheme in operation in your country.

In parts of Europe and some other markets, extended warranty may be available to customers who register their purchase with the local Lindemann distributor. A warranty registration card is included with the product and should be stamped by your retailer and returned to the local distributor as soon as possible.

Warning

Unauthorised servicing or dismantling of the product invalidates the manufacturer's warranty. There are no user serviceable parts inside the product and all enquiries relating to product servicing should be referred to authorised retailers only.

Technical support and information

For technical support, product queries and information, please contact either your local retailer, the local Lindemann distributor or Lindemann audiotechnik. Full details of your local distributor can be found on the Lindemann website: www.lindemann-audio.de

Important

- Please keep a copy of the sales receipt to establish the purchase date of the product.
- Please ensure that your equipment is insured by you during any transit or shipment for repair.

Lindemann audiotechnik GmbH

Carl-Benz-Straße 12
D-82205 Gilching
Germany
Tel: +49 (0)8105-7785-30
Fax: +49 (0)8105-7785-55
Website: www.lindemann-audio.de
E-mail: info@lindemann-audio.de
service@lindemann-audio.de

Directive on waste electrical and electronic equipment

Electronic equipment should not be disposed of with household waste but in compliance with the Directive 2002/96/EU of the European Parliament and of the Council of 27 January 2003 on waste electrical and electronic equipment. When this equipment reaches the end of its working life, please take it to one of the available collection points.

The symbol (below) is attached to this product.



